

# PlateRite 2055VR

Flatbed Violet Plate Recorders



Creating a Future in Print

## Fast, high-quality, automated CTP-at an affordable price

**Dainippon Screen's PlateRite 2055VR is a reasonably priced 4-page (B2) format computer to plate (CTP) recorder that is ideal for users of 4-page presses who want to add CTP to their platemaking arsenal. CTP technology provides high quality and repeatability, and reduces costs by cutting out intermediate processes. The PlateRite 2055VR offers all the benefits of CTP in an affordable, high-quality unit that is designed to function in place of, or side by side with, imagesetters in a 4-page output production environment.**



### High quality and terrific automation without the hefty price tag

#### Affordable CTP for 4-page (B2) printing

The PlateRite 2055VR offers high-quality CTP output in an affordable, compact, flatbed unit. And it isn't only the initial cost of the unit that is reasonable—to help keep maintenance costs even lower, the imaging system features a long-lasting violet laser light-source. The PlateRite 2055VR is even space-efficient—its footprint is just 1,985 x 984 mm (78.2" x 38.8").

#### High productivity and high quality

The PlateRite 2055VR supports plate sizes ranging from 450 x 280 mm to 754 x 635 mm (17.7" x 11.0" to 29.7" x 25.0")\*, and can output an impressive 28 plates/hour at 1,200 dpi\*\*, all while maintaining consistently high quality. With this kind of productivity, throughput is sure to increase dramatically, even for jobs that demand particularly high-quality output.

\*Semi-automatic loading type: 450 x 280 mm to 760 x 635 mm (17.7" x 11.0" to 29.9" x 25.0")

\*\*Autoloading type.

#### Optional autoloader cassette for 50 plate batch processing

The PlateRite 2055VR can be operated with an optional autoloader cassette that holds up to 50 plates. This autoloader cassette features automatic interleaf detection and removal, as well as continuous plate feeding, and enables the unit to process up to 50 plates without operator intervention. The PlateRite 2055VR can be connected to an optional inline processor that creates a fully automated process from start to finish.

#### Increased productivity with optional punch systems

The PlateRite 2055VR can be equipped with optional internal punch systems. When internal punch systems are used, the plates are punched immediately after being mounted on the bed. This method provides much greater registration accuracy than either manual or offline punching, eliminates human error, and allows faster press makeready, for increased overall productivity.

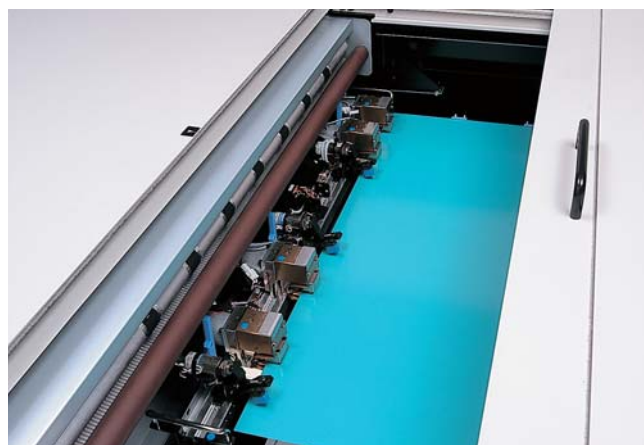

#### Automatic loading and unloading

The PlateRite 2055VR makes life easy for your operators by handling everything from plate loading to developing automatically\*. It can hold up to 50 plates in its media cassette, making it easy to output long runs of multiple pages with minimal effort.

\*When used with the optional inline processor.

Illustration shows the PlateRite 2055VR with autoloader.

Flatbed imaging system with violet laser diode

Loading sensor automatically distinguishes interleaf sheets and routes them to interleaf disposal area.

High accuracy flatbed transport system

Cassette sensor reads cassette ID code and automatically determines media type.

Internal punch supported

## Interleaf removal

The PlateRite 2055VR features an advanced interleaf removal system that reduces operator labor. After determining if the top sheet in the cartridge is metal or paper, the system automatically routes paper to the interleaf disposal area and plates to the imaging table. The operator can remove the waste paper from the disposal area at his or her leisure.

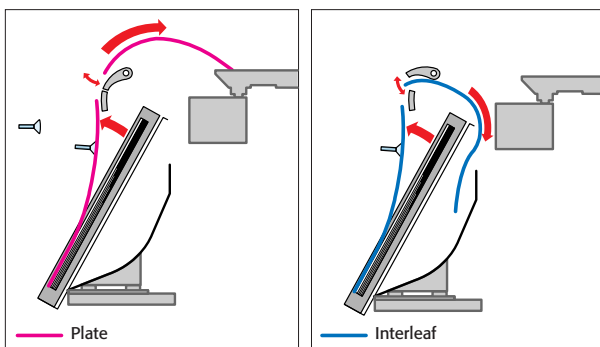

## Automatic recall of preset cassette parameters

The PlateRite 2055VR simplifies the output workflow by accepting preset parameters for a variety of printing presses and media sizes. Parameters include plate size: grip/anti-grip size: image centering: margins: and punch configuration. Media cassettes, which each feature an ID code, can be assigned a media type and destination. The recorder automatically reads the ID code when the cassette is inserted and recalls the appropriate data. This eliminates the time and trouble involved in entering this data each time the cassette is changed.

## Precision plate placement

Unlike many drum platesetters, the Flatbed PlateRite 2055VR doesn't subject plates to any strain during loading. It simply loads them onto the table as is. This both protects the plates and makes it easy to handle a wide variety of plate sizes with precision. A special plate placement system assures that plates are in the right position on the table, and a vacuum securing system prevents subsequent movement. The PlateRite 2055VR's low-stress handling and accurate plate placement system combine to offer the imaging precision required even for demanding, high-quality work.

## Smooth and accurate table movement

Precision imaging requires precision movement. The PlateRite 2055VR's imaging table moves across the imaging area with the aid of a precisely engineered transport system. Since the table moves in only one plane, its movement is extremely stable and regular. The smooth motion assures that the laser beam is just where it is needed at all times, so you get high repeatability even at high resolutions.

## Space requirements

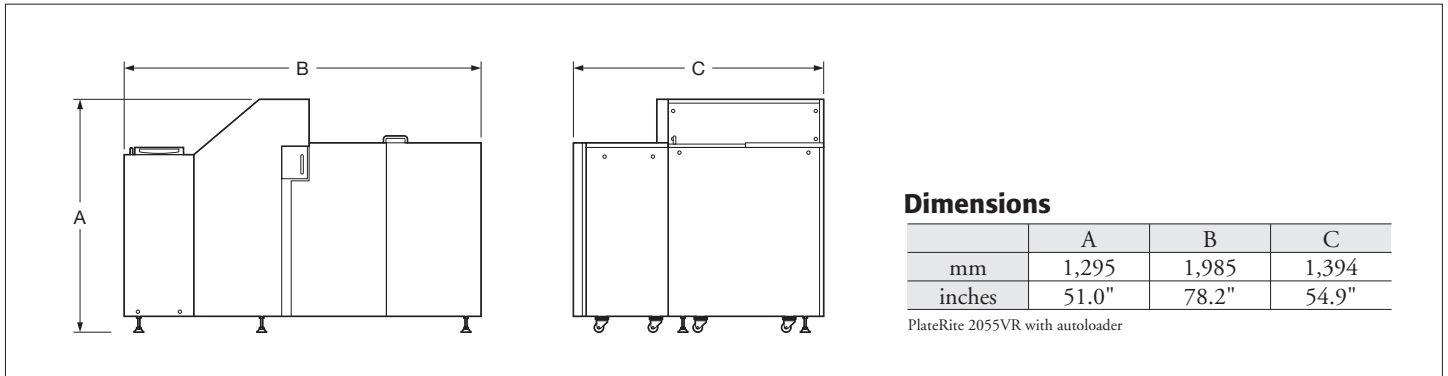

## PlateRite 2055VR specifications

Recording system	Primary scanning: Polygon mirror Secondary scanning: Flatbed with stepping motor
Light source	60mW Violet laser diode
Plate size	Semi-automatic loading: Maximum 760 x 635 mm (29.9" x 25.0") Minimum 450 x 280 mm (17.7" x 11.0") Autoloading: Maximum 754 x 635 mm (29.7" x 25.0") Minimum 450 x 280 mm (17.7" x 11.0")
Maximum imaging size	Semi-automatic loading :760 x 575 mm (29.9" x 22.6")* Autoloading :754 x 575 mm (29.7" x 22.6")**
Media	Violet sensitive photo polymer aluminum plates***
Media thickness	0.15 to 0.3 mm (5.9 to 11.8 mil)
Resolutions	1,200/2,400/3,000 dpi
Productivity	28 plates/hr at 1,200 dpi (754 x 635 mm / 29.7" x 25.0")****
Interface	F-PIF
Plate transport	Semi-automatic loading (standard) Fully automatic loading with interleaf removal (optional)
RIP	HQ-510 series, Trueflow SE Rite, Trueflow SE
Options	Autoloader (cassette capacity: maximum 50 plates) Extra supply cassette Punch systems (up to two)
Dimensions (W x D x H)	Semi-automatic loading: 1,985 x 984 x 1,295 mm (78.2" x 38.7" x 51.0") Autoloading: 1,985 x 1,394 x 1,295 mm (78.2" x 54.9" x 51.0")
Weight	Semi-automatic loading: 445 kg (981 lbs.)/Autoloading: 600 kg (1,323 lbs.)
Environment	During operation: 21 to 25°C (69.8 to 77°F), 50 to 70% relative humidity (non-condensing) During pause: 15 to 33°C (59 to 91.4°F), 30 to 80% relative humidity (non-condensing)
Power requirements	Single phase 200 to 240V (50/60Hz), 3.5A, 0.7 kW

\*Image quality can be guaranteed for images up to 760 x 550 mm ((29.9" x 21.7"))

\*\*Image quality can be guaranteed for images up to 754 x 550 mm (29.7" x 21.7")

\*\*\*A yellow light suitable for use with violet-sensitive media is required for use of the semi-automatic loading type.

\*\*\*\*With autoloader

## DAINIPPON SCREEN MFG. CO., LTD.

### HEAD OFFICE

• Teranouchi-sagaru 4-chome, Horikawa-dori, Kamigyō-ku, Kyoto, 602-8585 Japan/Phone +81-75-414-7610/Fax +81-75-414-7608

### SCREEN (USA)

• 5110 Tollview Dr., Rolling Meadows, IL 60008, USA/Phone 847-870-7400/Fax 847-870-0149 www.screenusa.com

### DAINIPPON SCREEN (DEUTSCHLAND) GmbH

• Mittelheimer Weg 39, 40472 Düsseldorf, Germany/Phone 0211-472701/Fax 0211-4727199/Telex 858-4438 DSDD D

### DAINIPPON SCREEN (U.K.) LTD.

• Michigan Drive, Tongwell, Milton Keynes, Buckinghamshire MK15 8HT, UK/Phone 01908-848500/Fax 01908-848501 www.screen.co.uk

### DAINIPPON SCREEN (NEDERLAND) BV

• Bouwerij 46, 1185 XX Amstelveen, Holland/Phone 020-4567800/Fax 020-4567805 www.screen-europe.com

### SCREEN FRANCE

• Z.I. Paris Nord II, 12 Rue des Chardonnerets, B.P. 50315, F-95940 ROISSY C.D.G. Cedex, France/Phone 1-48-17-86-00/Fax 1-48-17-86-01

### DAINIPPON SCREEN SINGAPORE PTE. LTD.

• 29, Kaki Bukit View, Kaki Bukit Techpark II, Singapore 415963/Phone 67493833/Fax 67499010 www.screen-sp.com.sg

### DAINIPPON SCREEN (CHINA) LTD.

• 6th Floor, 414 Kwun Tong Road, Kwun Tong, Kowloon, Hong Kong/Phone 2953-0038/Fax 2755-8683

Beijing office/Phone 010-6708-9271, 9272, 9273/Fax 010-6505-4975 (China)

Shanghai office/Phone 021-6466-4501/Fax 021-6466-4503 (China)

Guangzhou office/Phone 020-3991-1112/Fax 020-3991-1036 (China)

### DAINIPPON SCREEN (TAIWAN) CO., LTD.

• 4F No. 126-1, Ming Tsu West Rd., Taipei, Taiwan/Phone 02-25862711/Fax 02-25914367

### DAINIPPON SCREEN (KOREA) CO., LTD.

• 10th Yonsei Bongsae B/D 48-3, 1Ga, Bongsae-Dong, Joong-Gu, Seoul 100-161, Korea/Phone 02-7766-786/Fax 02-7766-787

### DAINIPPON SCREEN (AUSTRALIA) PTY. LTD.

• Unit 2, 207-209 Young Street, Waterloo, NSW 2017, Australia/Phone 02-9310-1314/Fax 02-9310-3566

Internet web site: [www.screen.co.jp](http://www.screen.co.jp)

- Printed on recycled paper.
- This brochure was printed using Spekta AM/FM hybrid screening.

We reserve the right to alter product design and specifications without prior notice.