

# Quartz Supreme Pre-bake Oven 85 / 125



## Uniform heating to ensure high processing quality

The Quartz Supreme Pre-bake Oven is designed to deliver precise and uniform pre-baking of thermal plates ensuring consistently high processing quality. At one of three pre-selected conveyor speeds the plates are run through the oven. The balanced air flow ensures an exceptional heating uniformity across the plate within  $\pm 2^{\circ}\text{C}$ .

Without compromising processing quality pre-baking with Quartz Supreme Pre-bake Oven has been made faster, easier, and more economical.

State-of-the-art new GNUCII electronics and control have been implemented in the new generation of Supreme post-bake ovens - giving the user full and easy control of the temperature and speed of the four selectable programs. These programs can be programmed with the wanted speed and temperature for individual plate types.

A new conveyor program is developed in connection with the Supreme Post-bake Ovens and consists of a range of individual input and output conveyors.



**Many optional features**  
Quartz Supreme Pre-bake Oven shown with front fume extraction cover, 500 mm driven feed table and rear heat extraction unit (all optional features).



**Optimal working environment**  
The hinged fume extraction cover optimises airflow ensuring user-friendly environment.

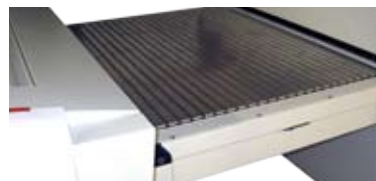

**Driven Slat Conveyor**  
An exit-conveyor for correct cool down of plates after baking.



**Simple and easy operation**  
Select one of the pre-programmed programmes, turn the oven on, and it will be ready when the set temperature in the selected program is reached.

Technical specifications:

# Quartz Supreme Pre-bake Oven



- Rugged Glunz & Jensen construction ensures reliable and trouble-free operation
- Flexible operation - integrates with all plateline configurations and is adjustable to suit all plate processors
- Very easy to operate - the newly developed Pre-bake oven is based on more than 30 years design experience of ovens
- Optional features to remove hot air and fumes ensuring user-friendly environment

	85	125
Process speed	0.50-1.0-1.5 m/min (19.7-39.4-59.1"/min)	0.85-1.0-1.3 m/min (33.5-39.4-51.2"/min)
Plate width, max.	850 mm (33.5")	1250 mm (49.2")
Plate length	2000 mm	2000 mm
Plate thickness	0,4 mm	0,4 mm
Temperature range	Ambient to 175 °C (347 °F)	Ambient to 175 °C (347 °F)
Power supply	400V 50/60Hz 3W + N + PE or 230V 50/60Hz 3W + PE	
Voltage tolerance	-10 / -14%	-10 / -14%
Power required	230 Vac, 32 A, 14.5 kW 400 Vac, 20 A, 14.5 kW	230 Vac, 32 A, 14.5 kW 400 Vac, 20 A, 14.5 kW
Note: Power consumption reduces by approximately two-thirds after warm-up period.		
BTU: Warm up / Stand-by or idle	49646 / 14500	49646 / 14500

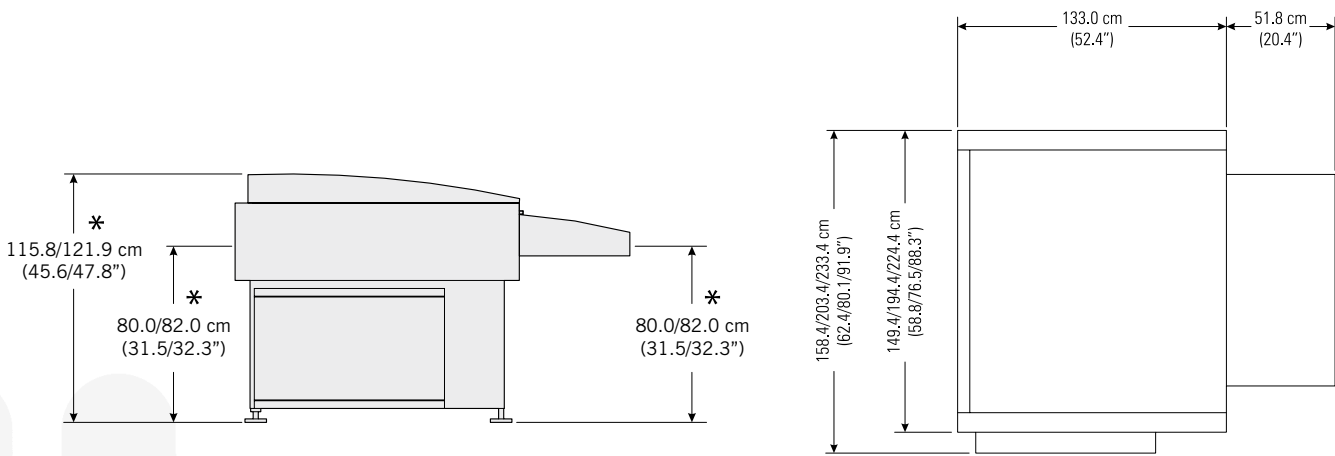

\* Height is adjustable up to 6,5 cm (2,56") upwards from the measurements listed above.

## GLUNZ & JENSEN

Headquarters:  
 Glunz & Jensen A/S  
 Haslevej 13  
 DK-4100 Ringsted  
 Denmark  
 Tel. +45 57 68 81 81  
 Fax +45 57 68 83 40  
 E-mail: gihq@glunz-jensen.com  
 Internet: www.glunz-jensen.com

USA Operations:  
 Glunz & Jensen, Inc.  
 21405 Business Court  
 Elkwood, VA 22718-1757  
 USA  
 Tel. +1 540 825-7300  
 Fax +1 540 825-7525  
 E-mail: usva@glunz-jensen.com

Glunz & Jensen K&F, Inc.  
 12633 Industrial Drive  
 Granger, IN 46530  
 USA  
 Tel: +1 574 272 9950  
 Fax: +1 574 277 6566  
 sales@k-f.com